

# Vrijstaande badmengkraan

## CR6057-2

1. Controleer de onderdelen zorgvuldig aan de hand van de onderdelenlijst hieronder. Neem contact op als er onderdelen ontbrek

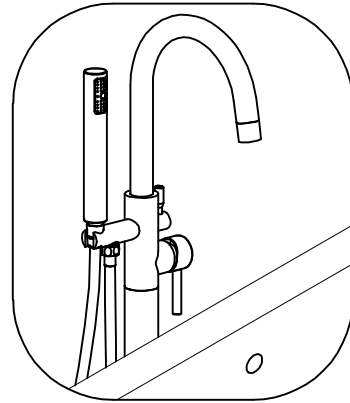

NO.	Name	Quantity
1	Kraanlichaam	1
2	Rechte buis	1
3	Sleutelschild	1
4	Flexibele slang	1
5	Driehoekig bevestigingsdeel	1
6	Verlengschroef	1
7	Handdouche	1
8	Doucheslang	1
9	Handschoenen	1
10	Montagehandleiding	1
11	Inbussleutel	1

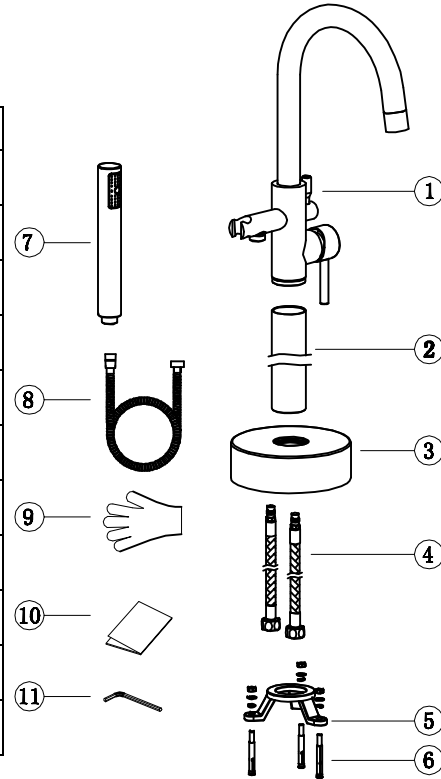

2. De hoogte van uw bad moet overeenkomen met de afmetingen van onze vrijstaande kraan.

1. Plaats eerst de rechte buis, het rozet en het driehoekige bevestigingsdeel in de flexibele slang. Sluit vervolgens de flexibele slang aan op het lichaam.

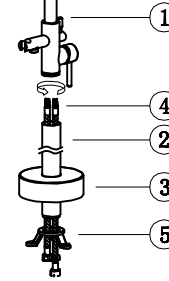

2. Verbind de rechte buis met het lichaam.

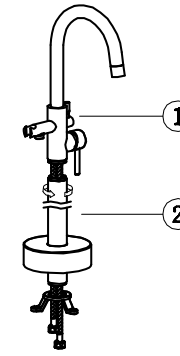

3. Installeer de inlaatleiding volgens de volgende tekeningen.

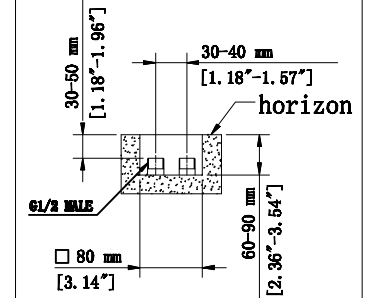

4. Sluit de flexibele slang aan op de inlaatpijp.

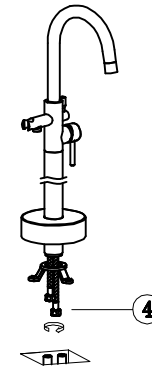

5. Bevestig het driehoekige bevestigingsdeel aan de rechte buis.

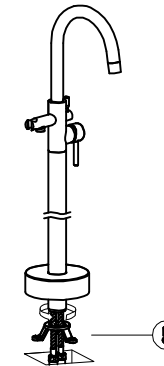

6. Boor het gat volgens de afmetingen op de tekening.

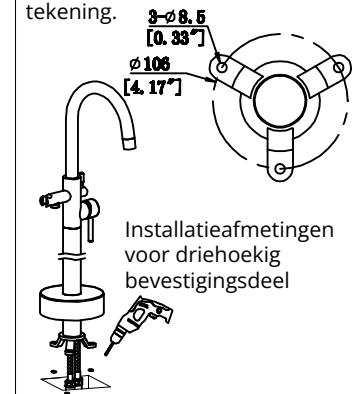

7. Installez le corps du robinet à l'aide d'une vis à expansion. Déplacez la rosace pour masquer la partie de fixation.

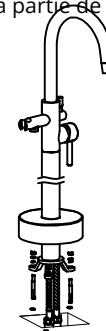

8. Installeer de handdouche en doucheslang.

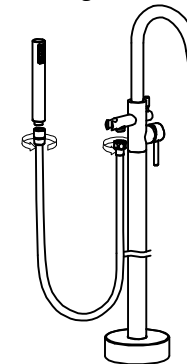

9. Totale assemblagetekening.

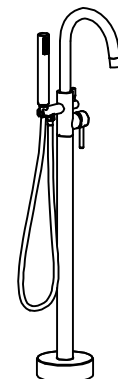

# Mitigeur de baignoire indépendant

**CR6057-2**

1. Vérifiez soigneusement les pièces à l'aide de la liste ci-dessous. Contactez-nous si des pièces manquent.

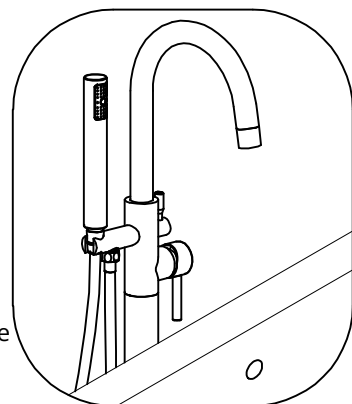

NO.	Nom	Nombre
1	Corps	1
2	Tube droit	1
3	Écusson	1
4	Tuyau flexible	1
5	Pièce de fixation triangle	1
6	Vis d'expansion	1
7	Douchette	1
8	Flexible de douche	1
9	Gants	1
10	Instructions	1
11	Clé hexagonale	1

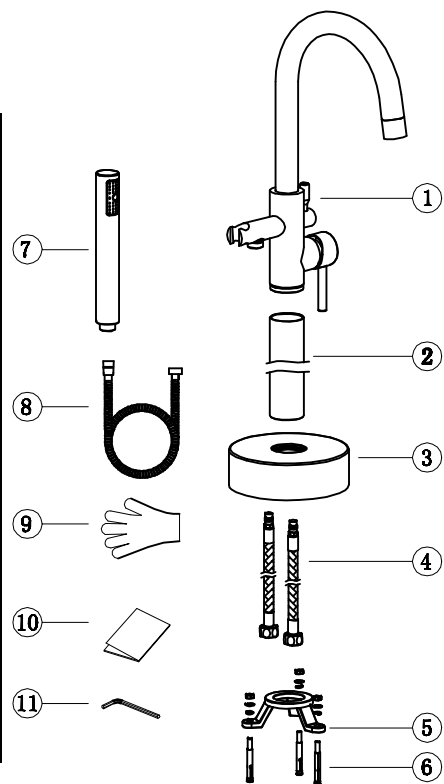

2. La hauteur de votre baignoire doit correspondre aux dimensions de notre robinetterie indépendante.

1. Insérez d'abord le tube droit, la rosace et la pièce de fixation triangulaire dans le tuyau flexible. Raccordez ensuite le tuyau flexible au corps.

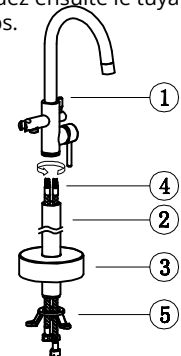

2. Connectez le tube droit au corps.

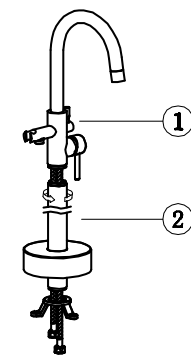

4. Raccordez le tuyau flexible au tuyau d'admission.

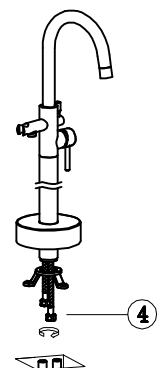

5. Fixez la pièce de fixation triangulaire au tube droit.

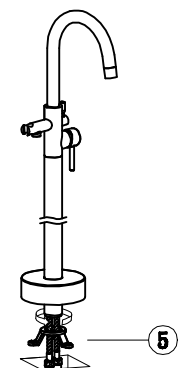

7. Installez le corps du robinet à l'aide d'une vis à expansion. Déplacez la rosace pour masquer la partie de fixation.

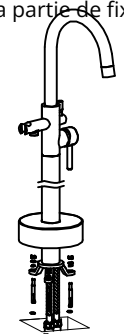

8. Installez la douchette à main et le flexible de douche.

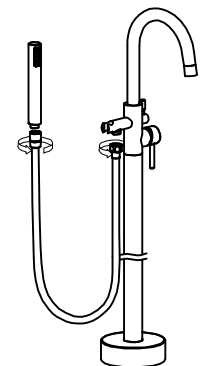

3. Installez la conduite d'admission conformément aux schémas suivants.

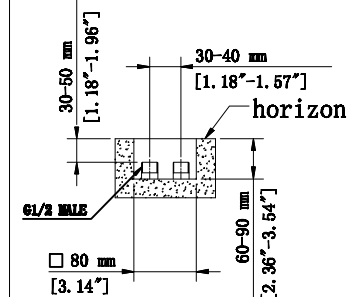

6. Percez le trou selon les dimensions indiquées sur le dessin.

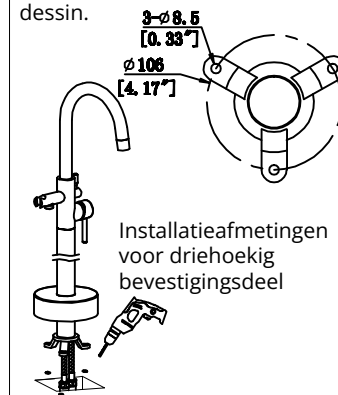

9. Dessin d'assemblage complet.



# Freestanding bath mixer

CR6057-2

1. Please check the parts carefully according to the standard parts list after you picking out the products. Please contact with the local distributor if any missing parts. See the drawings as below.

NO.	Name	Quantity
1	Body assembly	1
2	Straight tube	1
3	Escutcheon	1
4	Flexible hose	1
5	Triangle fixing part	1
6	Expansion screw	1
7	Hand shower	1
8	Shower hose	1
9	Gloves	1
10	Instructions	1
11	Hexagon key	1

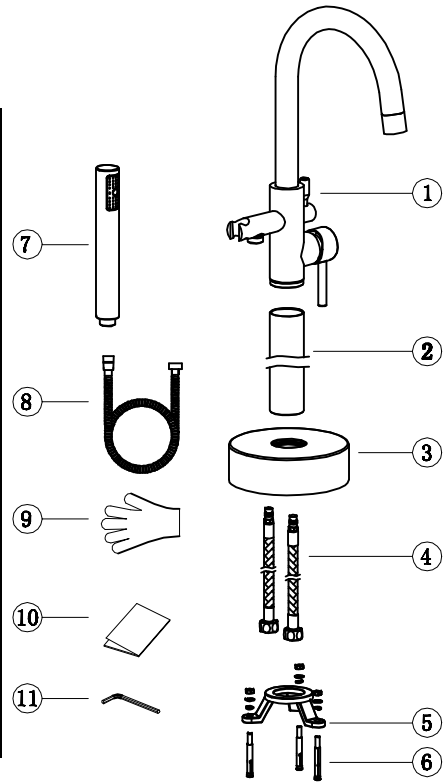

2. The height of your bath should match with the dimension of our free standing faucet.

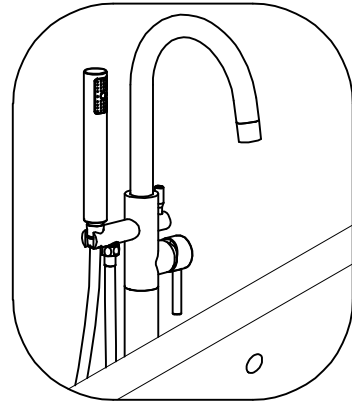

1. Firstly, bunch the straight tube, escutcheon and triangle fixing part into the flexible hose. Then connect the flexible hose to the body.

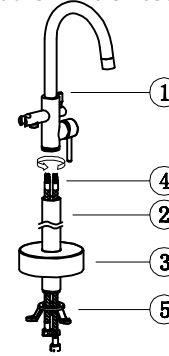

2. Connect the straight tube with the body.

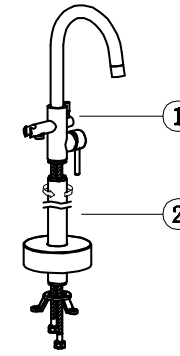

3. Install the inlet pipe per the following drawings.

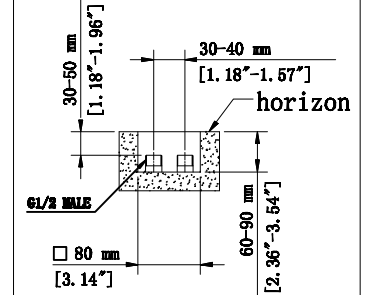

4. Connect the flexible hose to the inlet pipe.

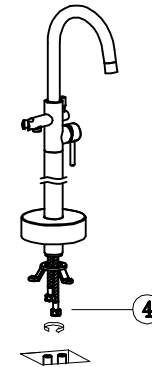

5. Connect the triangle fixing part to the straight tube.

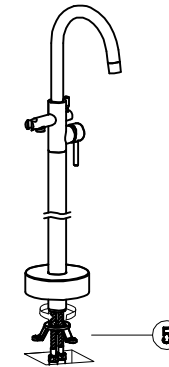

6. Drilling the hole per the drawing dimension.

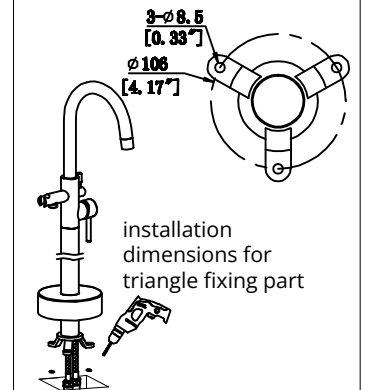

7. Install the faucet body by expansion screw. Move the escutcheon to hide the fixing part.

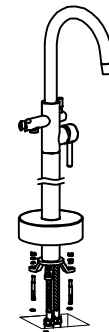

8. Install the hand shower and shower hose.

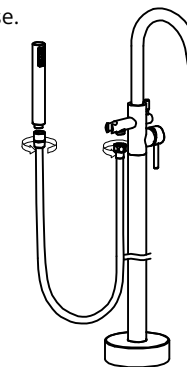

9. Total assembly drawing.

